

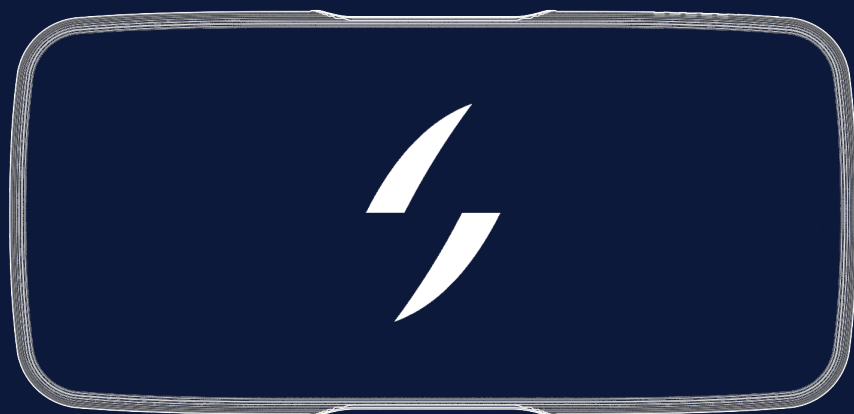

# Instruction Manual



 swytch

**Got an accessory?  
Scan here for instructions.**

<https://www.swytchbike.com/accessories/>



## Introduction

These are the original instructions for the Swytch eBike Conversion Kit. This is the Swytch Manual Version 012. The most up-to-date version of this manual can be found here and this should be consulted for any changes: [swytchbike.com/manual](http://swytchbike.com/manual).

Please read this manual as it contains important safety information and guidelines for how to get the most out of our Swytch Kit.

If you require this instruction manual in a different language, please contact us on [support@swytchbike.com](mailto:support@swytchbike.com).

## Safety Warnings



To ensure a safe and trouble-free experience when using your Swytch Conversion Kit please follow the guidelines below:

### **Kit intended use**

The Swytch Kit is designed for roads and well-made paths. It's not intended for drops of more than 10cm, stunts, cross-country riding, or extreme sports. Misuse may lead to the failure of some components and void your warranty.

The product must be used in compliance with your local laws and legislation.

### **Fully charge before first use**

As soon as you receive your kit fully charge your Power Pack, the light will go from red to green. Do this before you start fitting the Kit.

### **Never leave on charge for longer than necessary**

The Power Pack is perfectly safe for home use, but the charger and battery will gradually and naturally heat up when it's plugged in. Avoid leaving your Power Pack on charge for longer than necessary as this can lead to reduced battery life.

### **Power Pack Warnings**

When using, please follow the manual instructions. The battery must not be exposed to temperatures below  $-10^{\circ}\text{C}$  or above  $40^{\circ}\text{C}$ . The battery contains dangerous substances, and you must not disassemble, impact, or soak it in water. Only use the charger provided to charge the battery and when in storage you must charge every 90 days.

### **The handlebar mount handle must be fully engaged with the Power Pack**

The Power Pack must be fully connected within the mount for correct operation. The Power Pack should sit vertically within the mount with the logo facing forwards and the yellow connector at the top.

### **Tighten up before riding**

Whether it's your first ride or your hundredth ride, please ensure all nuts, screws and bolts are tight before taking off on the road. Any loose parts could result in the motor wheel coming off while riding - please be careful. Every 100 km, check your wheel spokes are tight to ensure that the wheel remains secure.

### **Maintain your bike**

For a safe ride on any bicycle, it's important that the bike is well-maintained and in good working order. Regularly check and maintain the condition of your bike. Placing any metallic or conductive objects into the charge port other than the charger may cause electric shock, fire or other injury. Don't connect the charger if water, ice or condensation is in the charge port.

Before you ride your Swytch Bike for the first time, please be sure that it has been correctly assembled. You'll find step by step instructions in this manual. For further help and support visit our help centre - [support.swytchbike.com](https://support.swytchbike.com)

### **Spares**

Only genuine replacement parts for safety-critical components must be used. There are no consumables or lubricants necessary for the Swytch Kit. Please contact our help centre for more information about spares.

### **Warnings**

Throughout the manual these callouts warn about situations that could cause death, serious injury and/or heavy material damage if you don't follow the safety instructions.



### **Get in touch**

Before you ride your Swytch Bike for the first time, please be absolutely sure that it has been correctly assembled. You will find step-by-step instructions in this manual. For further help and support visit our help centre here - [support.swytchbike.com](https://support.swytchbike.com).

**As required by the EPAC standard, the A-weighted emission sound pressure level from the Swytch kit does not exceed 70 dB(A).**



## **Avertissements de sécurité**

Pour éviter tout risque ou problème durant l'utilisation de votre kit de conversion Swytch, respectez les directives ci-dessous:

### **Utilisation prévue du kit**

Le kit Swytch est conçu pour être utilisé sur les routes et les chemins bien tracés. Il n'est pas prévu pour les différences de niveau de plus de 10 cm, les cascades, le tout-terrain ou les sports extrêmes. Une utilisation abusive peut entraîner la défaillance de certains composants et annuler votre garantie.

Le produit doit être utilisé conformément aux lois et à la législation de votre pays.

### **Effectuez une charge complète avant la première utilisation**

Dès que vous recevez votre kit, chargez complètement votre Power Pack, le voyant passera du rouge au vert. Faites-le avant de commencer l'installation du kit.

### **Ne laissez jamais le Power Pack en charge plus longtemps que nécessaire**

Le Power Pack est parfaitement sûr pour une utilisation à domicile, mais le chargeur et la batterie chauffent progressivement et naturellement lorsqu'ils sont branchés. Évitez de laisser votre Power Pack en charge plus longtemps que nécessaire, car cela peut entraîner une réduction de l'autonomie de la batterie.

### **Avertissements concernant le Power Pack**

Lors de l'utilisation, veuillez suivre les instructions du manuel. La batterie ne doit pas être exposée à des températures inférieures à -10°C ou supérieures à 40°C. La batterie contient des substances dangereuses et vous ne devez pas la démonter, lui faire subir des chocs ou la submerger dans l'eau. Utilisez uniquement le chargeur fourni pour charger la batterie. Pendant son stockage, vous devez la recharger tous les 90 jours.

### **La poignée de fixation au guidon doit être complètement engagée avec le Power Pack**

Le Power Pack doit être entièrement connecté dans la fixation pour un fonctionnement correct. Le Power Pack doit être placé verticalement dans la fixation avec le logo vers l'avant et le connecteur jaune en haut.

### **Serrez avant de rouler**

Que ce soit votre première ou votre centième sortie, vérifiez que tous les écrous, vis et boulons sont bien serrés avant de prendre la route. Toute pièce desserrée pourrait entraîner le détachement de la roue motrice pendant que vous roulez - soyez prudent. Tous les 100 km, vérifiez que les rayons de votre roue sont bien serrés pour vous assurer que la roue reste bien fixée.

## Entretenez votre vélo

Pour rouler en toute sécurité sur n'importe quel vélo, il est important qu'il soit bien entretenu et en bon état de marche. Vérifiez régulièrement l'état de votre vélo et entretenez-le. Si vous placez un objet métallique ou conducteur dans le port de charge autre que le chargeur, vous risquez de provoquer un choc électrique, un incendie ou d'autres blessures. Ne branchez pas le chargeur s'il y a de l'eau, de la glace ou de la condensation dans le port de charge.

Avant d'utiliser votre vélo Swytch pour la première fois, vérifiez qu'il a été monté correctement. Vous trouverez des instructions détaillées dans ce manuel. Si vous avez besoin d'aide, consultez notre centre d'assistance - [support.swytchbike.com](https://support.swytchbike.com).

## Pièces de rechange

Vous devez utiliser exclusivement des pièces de rechange d'origine pour les composants critiques pour la sécurité. Aucun consommable ou lubrifiant n'est nécessaire pour le kit Swytch. Contactez notre centre d'assistance pour obtenir plus d'informations sur les pièces de rechange.

## Avertissements

Tout au long du manuel, ces rappels mettent en garde contre des situations susceptibles de provoquer la mort, des blessures graves et/ou des dommages matériels importants si vous ne respectez pas les consignes de sécurité.



## Nous contacter

Avant d'utiliser votre vélo Swytch pour la première fois, vérifiez très soigneusement qu'il a été monté correctement. Vous trouverez des instructions détaillées dans ce manuel. Si vous avez besoin d'aide, consultez notre centre d'assistance disponible ici- [support.swytchbike.com](https://support.swytchbike.com).

**Manuel d'instructions.  
Scannez Ici.**





# Veiligheidswaarschuwingen

Volg de onderstaande richtlijnen om een veilige en probleemloze ervaring te garanderen tijdens het gebruik van uw Swytch ombouwset:

## **Beoogd gebruik van set**

De Swytch Kit is ontworpen voor wegen en goed aangelegde paden. Hij is niet bedoeld voor vallen van meer dan 10cm, stunts, veldrijden of extreme sporten. Verkeerd gebruik kan leiden tot het kapot gaan van sommige onderdelen waardoor uw garantie niet meer geldig is.

Het product moet worden gebruikt in overeenstemming met uw lokale wet- en regelgeving.

## **Volledig opladen voor het eerste gebruik**

Zodra u de kit hebt ontvangen en u de Power Pack volledig hebt opgeladen, gaat het lampje van rood naar groen. Doe dit voordat u de kit begint te monteren.

## **Laat nooit langer opladen dan nodig is**

Het Power Pack is volkomen veilig voor thuisgebruik, maar de oplader en de batterij zullen geleidelijk en natuurlijk opwarmen als ze zijn aangesloten. Laadt uw Power Pack niet langer dan nodig op. Dit kan de levensduur van de batterij verminderen.

## **Power Pack-waarschuwingen**

Volg tijdens het gebruik de instructies in de handleiding. De batterij mag niet worden blootgesteld aan temperaturen onder  $-10^{\circ}\text{C}$  of boven  $40^{\circ}\text{C}$ . De batterij bevat gevaarlijke stoffen. Haal het dus niet uit elkaar, laat het niet vallen en maak niet nat. Gebruik alleen de meegeleverde oplader om de batterij op te laden. Als deze niet wordt gebruikt, moet u hem nog steeds elke 90 dagen opladen.

## **De handgreep voor montage op het stuur moet volledig op de Power Pack zijn aangesloten**

De Power Pack moet volledig met de houder zijn verbonden voor een correcte werking. De Power Pack moet verticaal in de houder zitten met het logo naar voren gericht en de gele connector aan de bovenkant.

## **Draai aan voordat u gaat rijden**

Of het nu uw eerste rit of uw honderdste rit is, zorg ervoor dat alle moeren, schroeven en bouten goed vastzitten voordat u de weg op gaat. Losse onderdelen kunnen ertoe leiden dat het motorwiel losraakt tijdens het rijden - wees voorzichtig. Controleer elke 100km of de spaken van uw wiel goed vastzitten om ervoor te zorgen dat het wiel goed blijft zitten.

## **Onderhoud van uw fiets**

Voor een veilige rit op elke fiets is het belangrijk dat de fiets goed onderhouden en in goede staat verkeert. Controleer en onderhoud regelmatig de staat van uw fiets. Het plaatsen van metalen of geleidende voorwerpen in de oplaadpoort anders dan de oplader kan elektrische schokken, brand of letsel veroorzaken. Sluit de oplader niet aan als er water, ijs of condens in de oplaadpoort zit.

Voordat u voor het eerst op uw Swytch Bike gaat rijden, moet u ervoor zorgen dat deze op de juiste manier is gemonteerd. In deze handleiding vindt u stapsgewijze instructies. Ga voor meer hulp en ondersteuning naar ons helpcentrum - [support.swytchbike.com](https://support.swytchbike.com)

### **Reserveonderdelen**

Er mogen alleen originele vervangende onderdelen voor veiligheidskritische delen worden gebruikt. Er zijn geen verbruiksartikelen of smeermiddelen nodig voor de Swytch Kit. Neem contact op met ons helpcentrum voor meer informatie over reserveonderdelen.

### **Waarschuwingen**

In de handleiding waarschuwen deze aanduidingen voor situaties die de dood, ernstig letsel en/of zware materiële schade kunnen veroorzaken als u de veiligheidsinstructies niet opvolgt.



### **Neem contact met ons op**

Voordat u voor het eerst op uw Swytch Bike gaat rijden, moet u er absoluut zeker van zijn dat deze correct is gemonteerd. In deze handleiding vindt u stapsgewijze instructies. Bezoek voor meer hulp en ondersteuning ons helpcentrum - [support.swytchbike.com](https://support.swytchbike.com).

**Handleiding.  
Scan hier.**







# Sicherheitshinweise

Um eine sichere und problemlose Verwendung Ihres Swytch-Umrüstkits zu gewährleisten, beachten Sie bitte die folgenden Richtlinien:

## **Verwendungszweck des Umrüstkits**

Das Swytch-Umrüstkit ist für Straßen und gut ausgebaute Wege bestimmt. Das Umrüstkit ist nicht für Fallhöhen von mehr als 10 cm, Stunts, Querfeldeinfahrten oder Extremsportarten vorgesehen. Unsachgemäße Verwendung kann zum Ausfall einiger Komponenten führen und Ihre Garantie erlischt.

Das Produkt muss in Übereinstimmung mit den Gesetzen und Vorschriften in Ihrem Land verwendet werden.

## **Vor dem ersten Gebrauch vollständig aufladen**

Sobald Sie Ihr Kit erhalten haben, laden Sie den Akku vollständig auf. Die Anzeige wechselt von rot auf grün, sobald der Akku vollständig geladen ist. Erledigen Sie dies, bevor Sie mit dem Einbau des Umrüstkits beginnen.

## **Führen Sie den Ladevorgang nie länger als nötig durch**

Beim Ladevorgang entwickeln das Ladegerät und der Akku/das Power Pack eine leichte Wärme, was völlig ungefährlich ist. Führen Sie den Ladevorgang nicht länger als nötig durch, da dies die Lebensdauer des Akkus verkürzen kann.

## **Akku-Warnhinweise**

Beachten Sie bei der Verwendung bitte die Anweisungen im Handbuch. Der Akku sollte Temperaturen von unter  $-10^{\circ}\text{C}$  oder über  $+40^{\circ}\text{C}$  nicht ausgesetzt werden. Er enthält gefährliche Substanzen und darf deshalb nicht zerlegt, beschädigt oder in Wasser eingetaucht werden. Verwenden Sie zum Aufladen des Akkus nur das mitgelieferte Ladegerät. Laden Sie den Akku alle 90 Tage auf, wenn Sie ihn nicht verwenden.

## **Die an der Lenkstange montierte Halterung muss fest mit dem Power Pack/dem Akku verbunden sein**

Der Akku muss vollständig in die Halterung eingesteckt sein, damit es richtig funktioniert. Der Akku sollte senkrecht in der Halterung sitzen, wobei das Logo nach vorne und der gelbe Stecker nach oben zeigt.

## **Vor der Fahrt festziehen**

Unabhängig davon, ob es sich um Ihre erste oder hundertste Fahrt handelt, stellen Sie bitte sicher, dass alle Muttern, Schrauben und Bolzen fest angezogen sind, bevor Sie sich auf die Straße begeben. Jedes lose Teil könnte dazu führen, dass sich das motorisierte Rad während der Fahrt löst – bitte seien Sie vorsichtig. Prüfen Sie alle 100 km, ob das Rad fest in der Gabel sitzt, um einen sicheren Halt des Rades zu gewährleisten.

## Instandhaltung Ihres Fahrrads

Für eine sichere Fahrt mit einem Fahrrad ist es wichtig, dass das Fahrrad gut gewartet und in einem guten Gebrauchszustand ist. Überprüfen und warten Sie regelmäßig den Zustand Ihres Fahrrads. Wenn Sie andere metallische oder leitende Gegenstände als das Ladegerät in den Ladeanschluss stecken, kann dies zu einem elektrischen Schlag, einem Brand oder anderen Verletzungen führen. Schließen Sie das Ladegerät nicht an, wenn sich Wasser, Eis oder Kondensat im Ladeanschluss befindet.

Bevor Sie Ihr Swytch-Bike zum ersten Mal fahren, vergewissern Sie sich bitte, dass es richtig zusammengesetzt wurde. In diesem Handbuch finden Sie eine Schritt-für-Schritt-Anleitung. Für weitere Hilfe und Unterstützung besuchen Sie unser Service-Center - [support.swytchbike.com](https://support.swytchbike.com)

## Ersatzteile

Für Bauteile, die die Sicherheit betreffen, dürfen nur Originalersatzteile verwendet werden. Für das Swytch-Kit sind keine Verbrauchsmaterialien oder Schmiermittel erforderlich. Bitte kontaktieren Sie unser Service-Center für weitere Informationen über Ersatzteile.

## Warnungen

Die Hinweise in diesem Handbuch sollen Sie vor Tod, schweren Verletzungen und/oder schweren Sachschäden schützen. Befolgen Sie deshalb bitte sämtliche Sicherheitsanweisungen.



## Nehmen Sie Kontakt auf

Bevor Sie Ihr Swytch-Bike zum ersten Mal fahren, vergewissern Sie sich bitte gründlich, dass es richtig zusammengesetzt wurde. In diesem Handbuch finden Sie eine Schritt-für-Schritt-Anleitung. Für weitere Hilfe und Unterstützung besuchen Sie hier unser Service-Center - [support.swytchbike.com](https://support.swytchbike.com)

**Gebrauchsanleitung.**  
**Hier scannen.**





## **Advertencias de seguridad**

---

Para garantizar que el uso del Kit de Conversión de Swytch sea seguro y sin problemas, respete las siguientes indicaciones:

### **Uso previsto del kit**

El Kit Swytch está diseñado para transitar por carreteras y por caminos en buen estado. No está diseñado para caídas de más de 10 cm ni para hacer trucos, transitar campo a través ni practicar deportes de riesgo. El uso indebido puede causar fallas en ciertos componentes y anular la garantía.

El producto se debe usar respetando la legislación y la normativa locales.

### **Cargue por completo antes del primer uso**

En cuanto reciba el kit, cargue la batería por completo, hasta que la luz roja cambie a verde. Hágalo antes de armar el kit.

### **Nunca deje el cargador conectado más tiempo del necesario**

Aunque la batería es perfectamente segura para el uso doméstico, es normal que tanto el cargador como la batería se calienten gradualmente al estar enchufados. No deje la batería cargando más tiempo que el necesario, ya que podría acortar su vida útil.

### **Advertencias sobre la batería**

Al usarla, respete las instrucciones del manual. La batería no debe exponerse a temperaturas menores que -10 °C ni mayores que 40 °C. Debido a que contiene sustancias peligrosas, no debe desarmarla, golpearla ni mojarla. Cargue la batería solamente con el cargador provisto; si la guarda durante mucho tiempo, debe cargarla cada 90 días.

### **El asa de la montura del manillar debe estar completamente conectada a la batería**

Para que el funcionamiento sea correcto, la batería debe estar completamente conectada dentro de la montura. La batería debe quedar en posición vertical dentro de la montura, con el logotipo hacia adelante y el conector amarillo hacia arriba.

### **Revise que todo esté apretado antes de usar**

Tanto en su primer viaje como en el número cien, compruebe que todas las tuercas, tornillos y pernos estén bien apretados antes de salir a la carretera. Cualquier pieza floja puede hacer que la rueda motriz se desprenda durante el viaje. ¡Tenga cuidado! Cada 100 km, revise que los radios de la llanta estén firmes, para confirmar que no hay peligro con la llanta.

### **Cuide su bici**

Para montar cualquier tipo de bicicleta, es importante que la bici esté bien mantenida y que funcione correctamente. Revísela periódicamente y haga el mantenimiento necesario. Si en el puerto de carga coloca cualquier tipo de objeto metálico o conductor distinto del cargador, puede provocar una descarga eléctrica, un incendio o lesiones. No conecte el cargador si hay agua, hielo o condensación en el puerto de carga.

Antes de usar la Bici Swytch por primera vez, asegúrese de que esté montada correctamente. Este manual contiene instrucciones detalladas de cómo hacerlo. Si necesita asistencia, visite nuestro centro de ayuda: [support.swytchbike.com](http://support.swytchbike.com).

### **Repuestos**

Use solo repuestos originales al reemplazar componentes esenciales para la seguridad. El Kit Swytch no necesita consumibles ni lubricantes. Si necesita información sobre los repuestos, comuníquese con nuestro centro de ayuda.

### **Advertencias**

En el presente manual, estos símbolos advierten sobre situaciones que podrían causar la muerte, lesiones graves y/o daños materiales importantes si no respeta las instrucciones de seguridad.



### **Póngase en contacto**

Antes de usar la Bici Swytch por primera vez, asegúrese muy bien de que esté montada correctamente. Este manual contiene instrucciones detalladas de cómo hacerlo. Si necesita asistencia, visite nuestro centro de ayuda aquí: [support.swytchbike.com](http://support.swytchbike.com).

**Manual de instrucciones.  
Escanee aquí.**



# Table of Contents

## 1

### In the Box

---

Kit Checklist	15
Tools Required	16

## 2

### Installation

---

Swytch Motor Wheel	18
Magnetic Disc(s)	23
Pedal Sensor	29
Mount & Bracket	31
Display	34
Connecting Up	35

## 3

### Brompton Specific

---

Torque Washer	39
Magnetic Disc(s)	40
Pedal Sensor	42
Bro Peg	43
Cable Routing	44

## 4

### Using Your Kit

---

Power Pack Intro	46
Starting Your Ride	47
Power Pack Settings	49
Checking Battery	51
Ending Your Ride	52
Charging Your Kit	53

## 5

### Troubleshooting

---

Error Codes	55
Motor Wheel	56
Pedal Sensor	57
Magnetic Disc(s)	57
Mount & Bracket	58

## 6

### Kit Care

---

Maintenance	60
Warranty Terms	61

# 1

## In the Box



Swytch Help Centre

1. Kit Checklist

2. Tools Required

# 1. Kit Checklist

Use this list to get all the parts ready before you start.



Power Pack

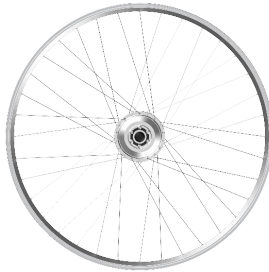

Motor Wheel



Mount



Bracket, Spacers  
& Screws



Display (1 of)  
Base  
LED  
OLED

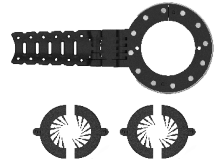

Magnetic Disc



Pedal Sensor

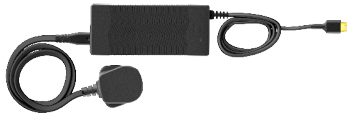

Charger



Cable Ties

\*Please note that this doesn't include any accessories.

## 2. Tools Required

You'll need to use the following tools to install your Kit. Please note that these are not provided.



Allen Key Set



Tyre Levers



Scissors



Bicycle Pump



Adjustable Spanner



Ruler



# 2

## Installation



Swytch Help Centre

1. Swytch Motor Wheel
2. Magnetic Disc(s)
3. Pedal Sensor
4. Mount & Bracket
5. Base Display
6. Connecting Up
7. Routing Cables

## 1. Swytch Motor Wheel

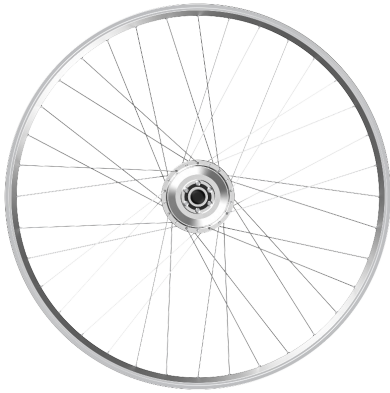

Your Swytch motor wheel has been built to the size and colour you specified. The wheel incorporates the 250W motor hub which is used to power your bike so it's important to assemble it securely into your forks.

### 1. Remove your front wheel

- 1.1 Turn your bike upside down. Loosen your existing front wheel and remove it.

#### **Note**

These steps depend on the brand and type of bike you have. Please see the manufacturer's instructions or visit [support.swytchbike.com](http://support.swytchbike.com) for support.



## 2. Prepare your Swytch motor wheel

- 2.1 Fit your Swytch motor wheel with a **new** tyre and inner tube. For support and advice on which tyre you should use visit [support.swytchbike.com](http://support.swytchbike.com).

If you don't have a new tyre, use the tyre and inner tube off the wheel you just removed from your bike.

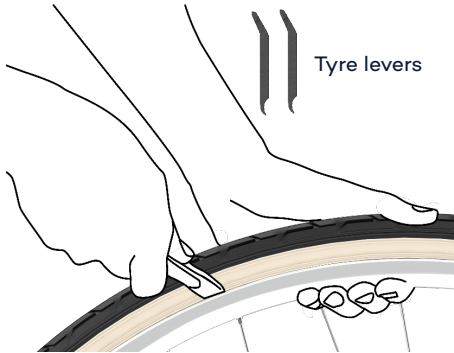

- 2.2 Pump up the tyre to the manufacturer's suggested tyre pressure. This is printed on the sidewall of the tyre.



- 2.3 If you have disc brakes, remove the six screws and plastic spacer from the motor wheel. Move the disc rotor from your old wheel onto your Swytch motor wheel.



- 2.4 Use the existing screws and hardware you have. The screws should have an 8mm thread length.



Ensure 2-3 Nm of torque is used. Visit [swytchbike.com/manual/3nm/](http://swytchbike.com/manual/3nm/) for support.



### 3. Fit the Swytch motor wheel onto your bike

3.1 Loosen the screws and slot the Swytch motor wheel into the dropouts of the forks.

 The motor cable should be on the **opposite** side to the chain.

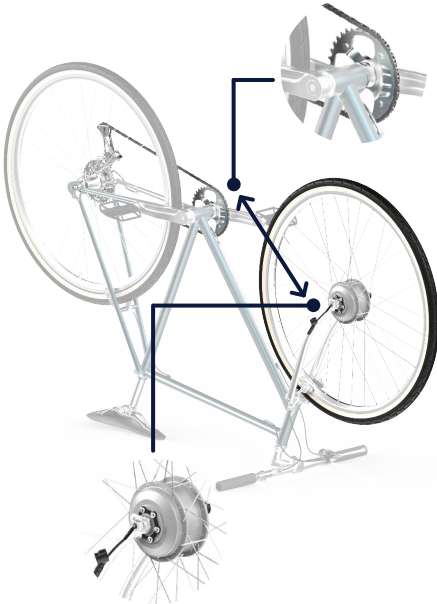

 The motor cable should face the ground when the bike is **upright**.

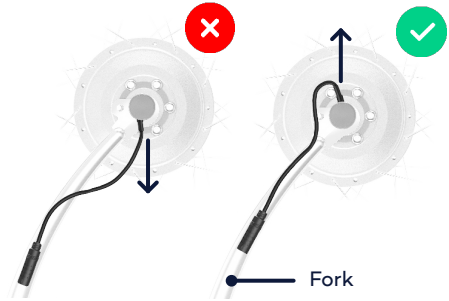

If at first it doesn't fit, check the axle flats are aligned with the fork dropouts.

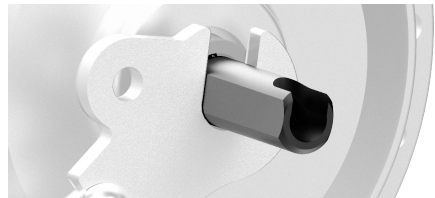

#### Note

Most bikes have a 10mm dropout slot width, so our standard motor axle is 10mm wide. If the axle doesn't fit your bike, please get in touch at [support.swytchbike.com](mailto:support.swytchbike.com) for options.

 Don't file your forks to make the motor wheel fit.

 When fitting the axle into the forks it is essential that it fits tightly. If there is any movement, or if the axle does not fit into the forks then you must get in touch with our support team. Do not attempt any modification without consent from an official Swytch Bike representative.



- 3.2 Fit the torque washer, flat washer, and axle nut as shown. Your bike forks should fit snugly around the lip of the torque washer. Depending on your order you will have received either a 9mm or 10mm torque washer.

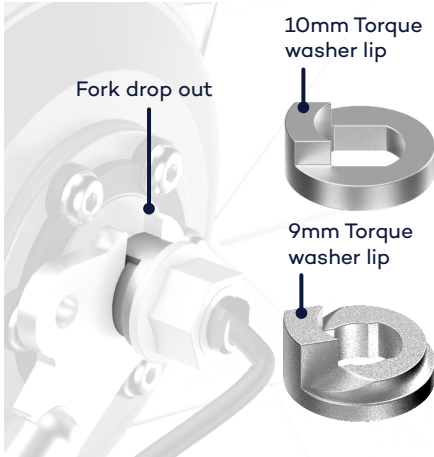

### Note

If you have a Brompton or other folding bike check page 39 for specific torque washer info.

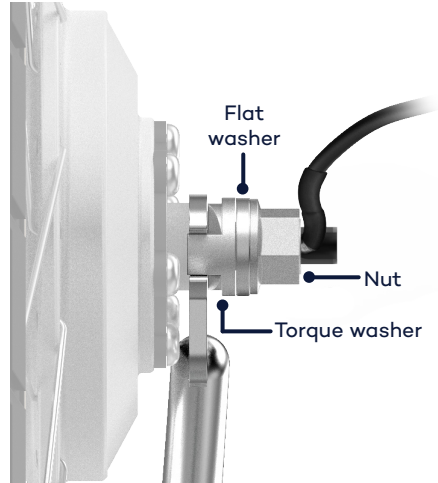

- 3.3 Using a large spanner, tighten the nuts on both sides of the motor wheel, applying enough force to the spanner that your knuckles turn white.

 Ensure 45 Nm of torque is used. Visit [swytchbike.com/manual/45nm/](http://swytchbike.com/manual/45nm/) for support.

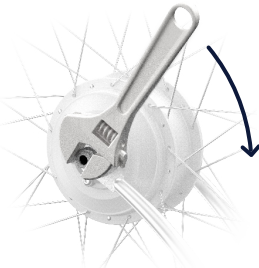

- 3.4 Fit the rubber cover over the nuts on both sides of the motor.

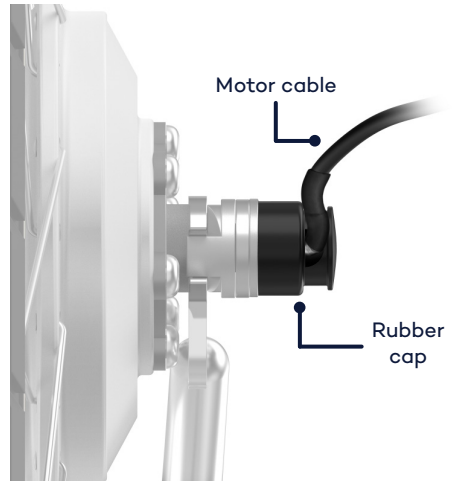

### Do you need a Torque Arm?



For carbon-fibre, and other types of weak forks, you may need a torque arm in addition to the torque washer to safely transfer the motor torque without damaging the forks.

View our Torque Arm Manual here. [www.swytchbike.com/help/manuals](http://www.swytchbike.com/help/manuals)



## 4. Check and adjust your brakes (if necessary)

- 4.1 If you have rim brakes, check the pads contact the new rim correctly. The brake pads should only touch the rim and not the tyre.

### Note

When adjusting the brakes follow the bicycle manufacturer's instructions.

If you're unsure about working on your brakes, visit [swytchbike.com/manual/adjustbrakes/](http://swytchbike.com/manual/adjustbrakes/) for support.

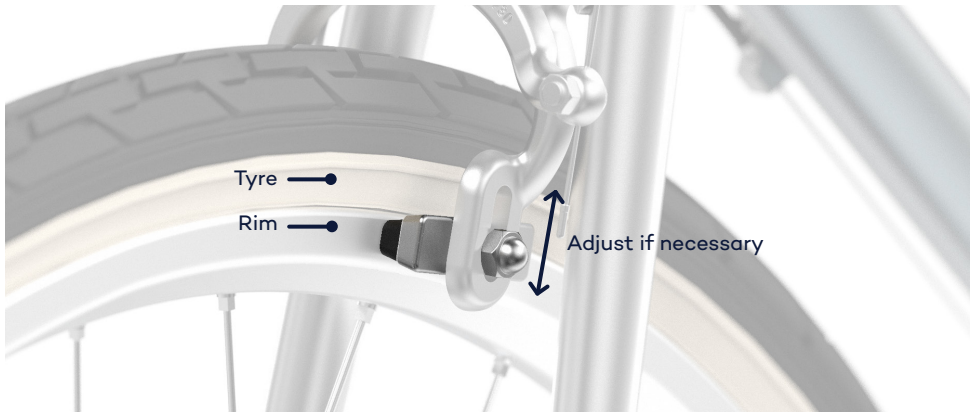

## 5. Check your motor wheel

- 5.1 Spin the motor wheel by hand. The wheel should spin freely.

Check the troubleshooting section if your wheel doesn't spin freely.



## 2. Magnetic Disc

The magnetic disc is used to detect when you're pedalling. It attaches to your bike's pedal arm.

There are extra inserts included to fit each style of bike. You can also flip the leg of it to get a better fit with your bike's pedal arm.

### Note

If you have a Brompton bike go to page 40.

Magnetic disc regular:

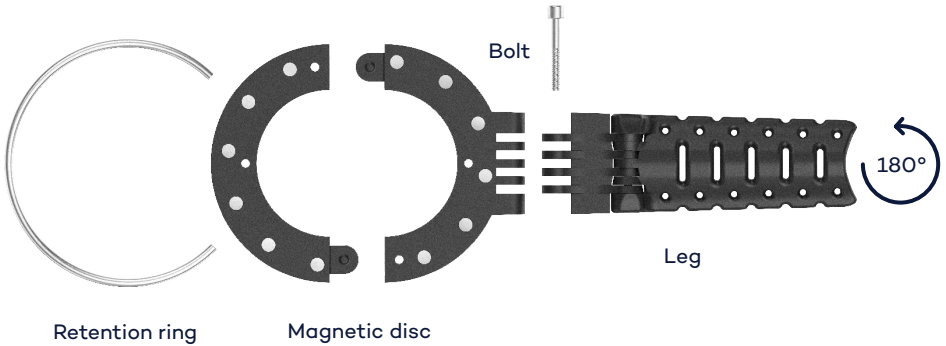

Inserts provided:

Easy fit **thin** inserts (2 pieces)

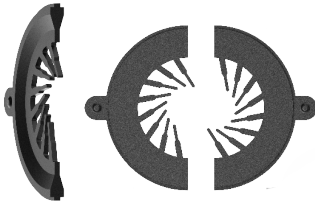

Easy fit **regular** inserts (2 pieces)

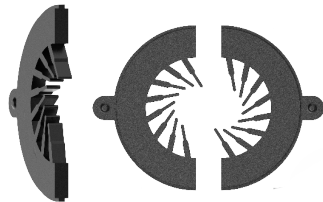

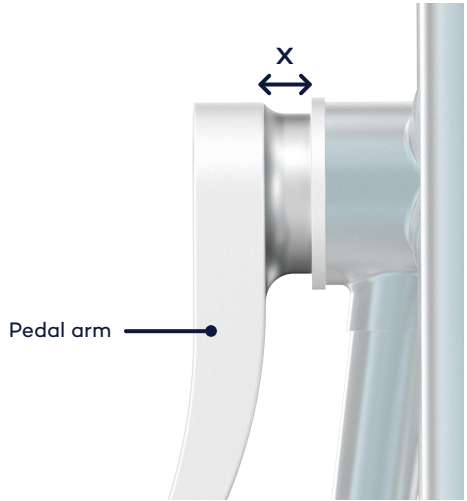

1. Determine if you need the inserts for your bike

- 1.1 Use a ruler to measure the gap between the end of the pedal arm and the start of the bike frame on the left side of the bike (opposite side to the chain).



2. Check the table below

- 2.1 Use the table below to determine which magnetic disc configuration you'll need for your bike.

x - Distance Between Pedal Arm and Frame	Configuration
2mm or less	Magnetic disc regular 
2mm - 4mm	Magnetic disc regular <b>with</b> Easy fit thin inserts 
4mm or more	Magnetic disc regular <b>with</b> Easy fit regular inserts 



### 3. Fit the correct inserts (if necessary)

- 3.1 The inserts can slot in facing either orientation, but ensure the spiral of the teeth aligns as shown.

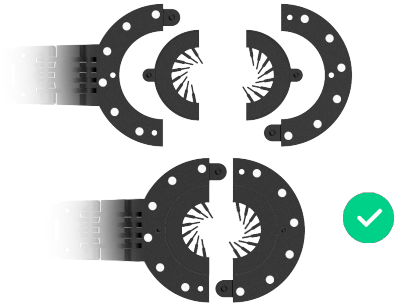

### 4. Determine if you need to flip the leg of the magnetic disc

- 4.1 Check which pedal arm your bike has from the two options below.

A. Round or Flat pedal arm

The **backside** of your pedal arm is flat or round.

The magnetic disc leg comes ready to fit for Round or Flat pedal arms (A) like shown. Skip to step 6.

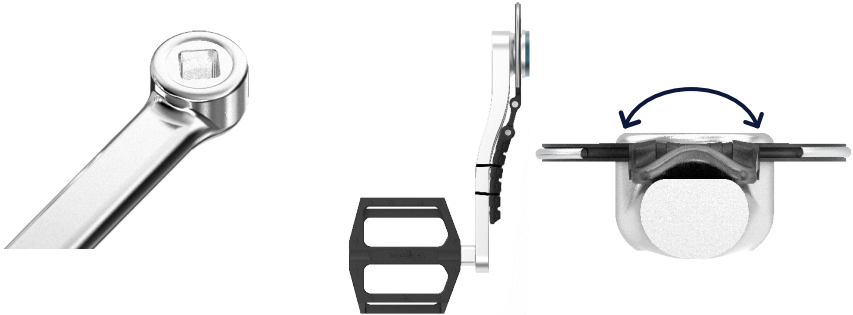

B. Indented pedal arm

The **backside** of your pedal arm has a concave indentation.

Check the next page for instructions on how to fit the leg to a concave pedal arm.



5. Flip the leg of the magnetic disc  
(Indented pedal arms only)

5.1 Unscrew the bolt using a 2.5mm Allen key. Take out the screw and the leg.

5.2 Flip the leg 180 degrees.

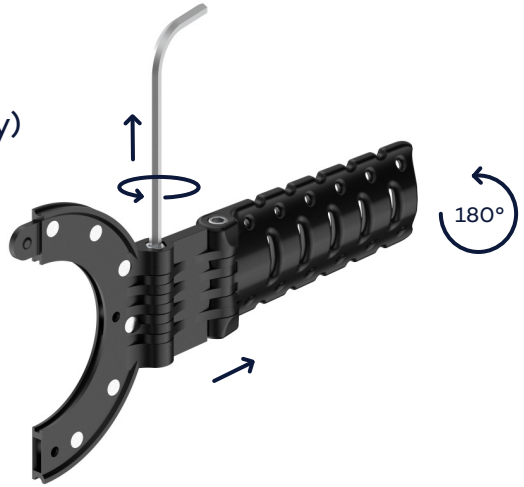

5.3 Place back the leg then screw and retighten.

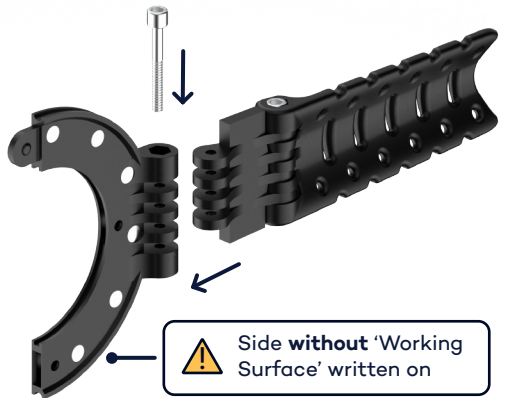

The contour of the leg now aligns with the concave recess of the pedal arm.

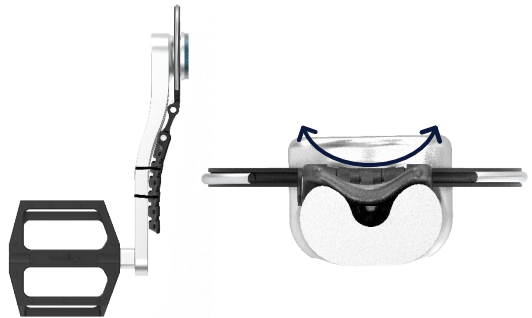

## 6. Fit the magnetic disc

- 6.1 Fit the magnetic disc around the crank axle, behind the pedal arm, on the side of the bike opposite the chain.

Check the side of the disc with **'Working Surface'** written is facing the bike frame.

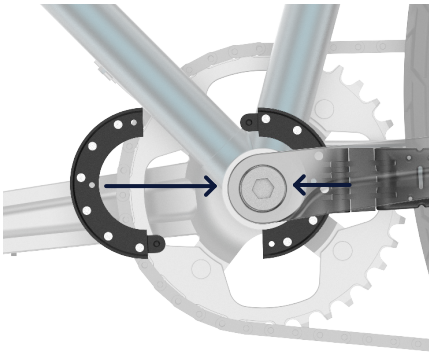

- 6.2 Push and click together the two halves of the magnetic disc.

### Note

If you have inserts the same instructions apply.

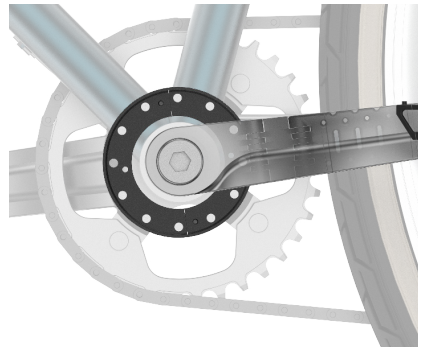

## 7. Fit the retention ring

- 7.1 Fit the retention ring around the magnetic disc to secure the two sides in place.

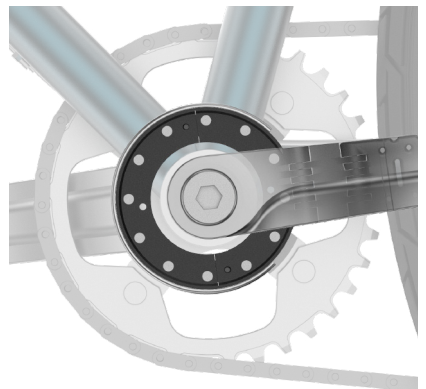
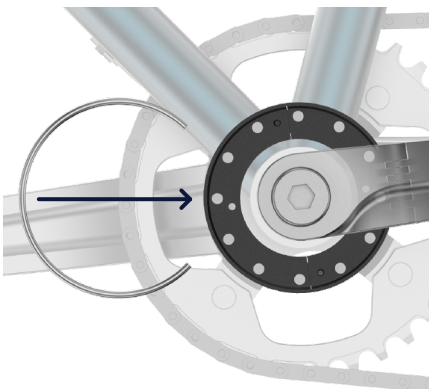

## 8. Secure the arm with cable ties

- 8.1 Loosely cable tie the magnetic disc arm to the inside of your pedal arm in at least two points.
- 8.2 Reposition the magnetic disc so that it is aligned as seen in the picture. Check that the alignment is correct by rotating the pedal arm backwards and watching for any movement.
- 8.3 After checking the alignment is correct, tighten the cable ties and bolts completely.

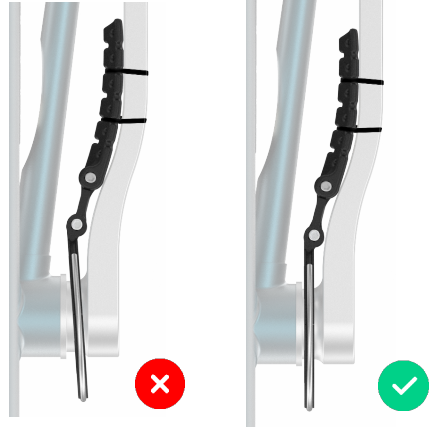

### Note

For narrow pedal arms, thread the cable ties through the holes to improve and tighten the grip.



## 9. Finished

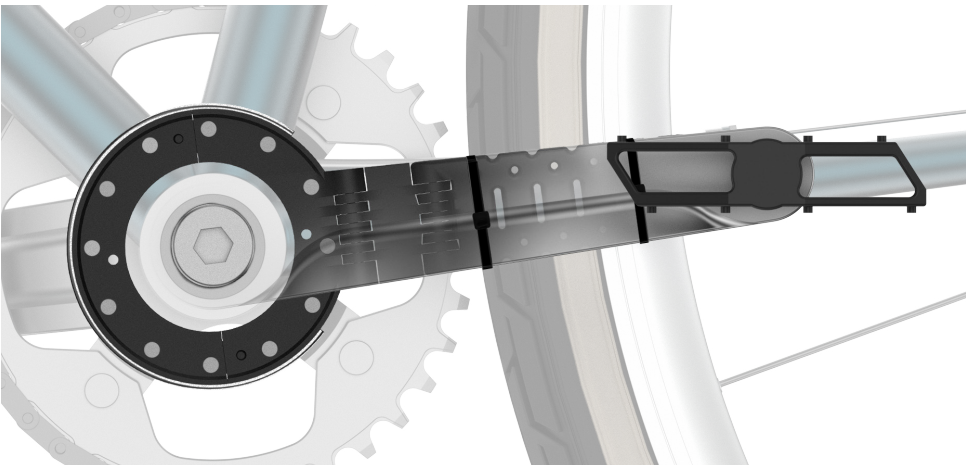

### 3. Pedal Sensor



The pedal sensor detects when you start to pedal, using the magnetic disc to determine your cadence. It then sends a signal to power the motor controller. The LED flashes red to indicate when it's working.

#### 1. Peel back the red cover

- 1.1 Peel back the red cover to show the adhesive layer.

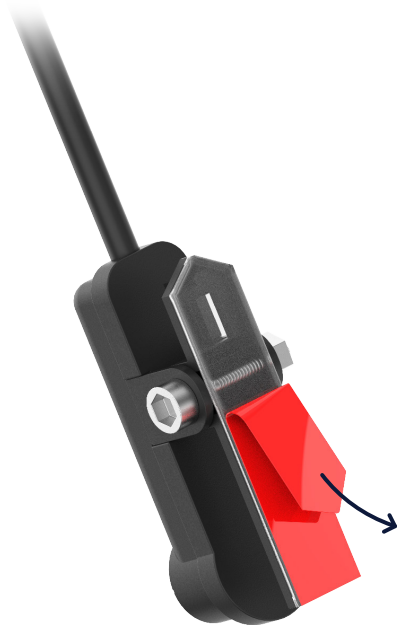

## 2. Line up the sensor, stick and secure

2.1 Stick the sensor to the side of your down tube on the frame as seen in the image below.

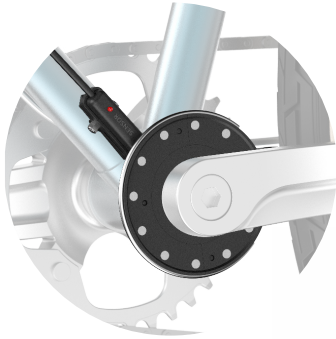

2.2 Ensure that the centre of the sensor is aligned with the magnets on the disc. There is a target on the sensor to help you line it up.

2.3 Add as many foam adhesive spacers needed to position the sensor within 3mm of the magnetic disc. Loosen the bolt to angle the sensor, then tighten and cable tie in place.

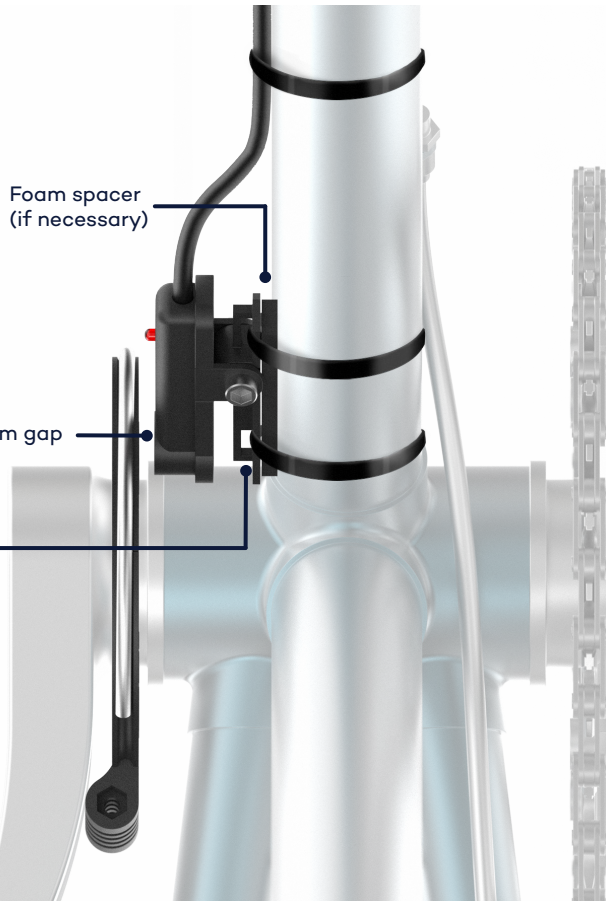
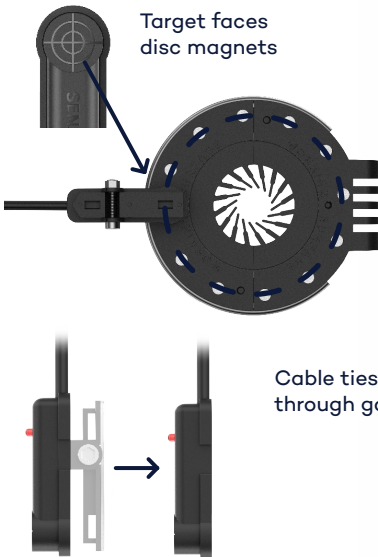

### Note

If there isn't enough space, cut off the plastic hinge piece of the sensor and mount directly using cable ties. This will **not** void your warranty.

## 4. Mount & Handlebar Bracket



The mount connects the Power Pack to the rest of the Swytch Kit system. It contains the controller and has a quick-release handle.

The bracket secures the mount to the handlebars. There are alternative brackets and adapters available that secure the mount to other parts of the bike.

**Note**

For carbon handlebars, check your manufacturer's manual if accessories such as clip-on TT bars are allowed to be mounted.

The handlebar bracket can be mounted in three different positions depending on your bike setup.



1. Standard mounting



2. High mounting



3. Security mounting  
(hidden screw access)

## 1. Place the mount under the handlebar

- 1.1 Position the mount on the centre of the handlebars, horizontal to the floor.



Route any brake or gear cables behind the mount. Check your brakes still work as normal.



## 2. Find the correct spacers size (if necessary)

- 2.1 Without a spacer, the bracket has a 31.8mm diameter.

If the bracket is loose on the handlebar, find a set of spacers to get a tight fit. There should be a small gap between the two spacers, as shown in the diagram below.

Spacer Options:



•22.2mm



••25.4mm



•••26mm

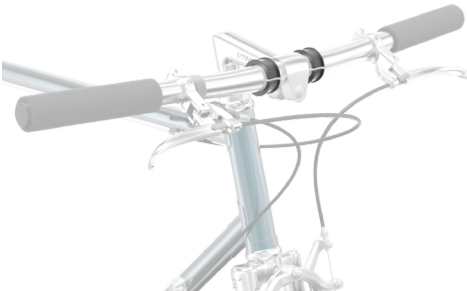

Too tight



Too loose



Perfect fit

Small gap



### 3. Assemble the bracket

- 3.1 Position together the lower and upper bracket halves, placing the spacers inside if they are required.

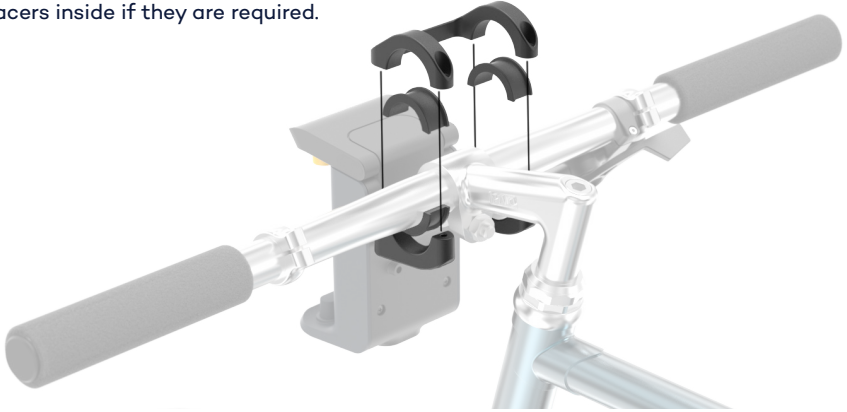

### 4. Screw the assembly together

- 4.1 To secure the mount in place screw the two bracket halves together using a 3mm Allen key. Make sure both halves are evenly tightened as shown below.

**Note**

Tighten the screws with 2-3 Nm of torque. Visit [swytchbike.com/manual/3nm/](http://swytchbike.com/manual/3nm/) for support.

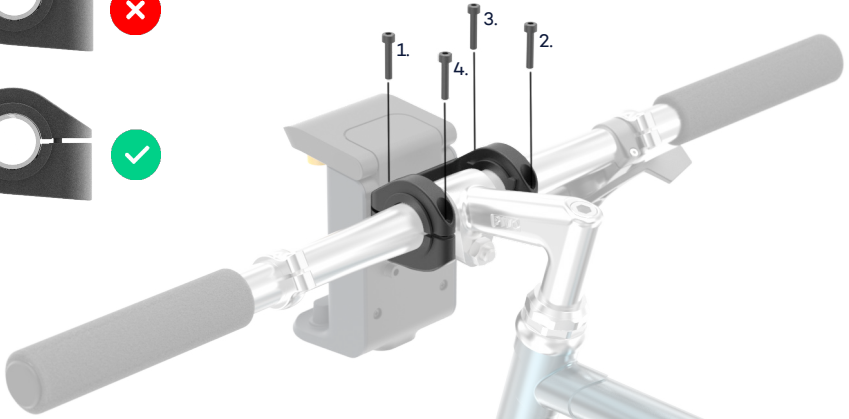
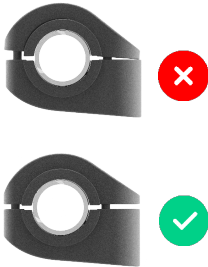

## 5. Installing the Display

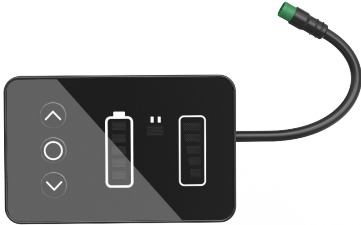

The displays allow you to control the Kit's power. You also use it to access the settings.

**Note**

The installation steps are the same for all types of displays. Scan the accessory QR code at the front of the manual to access the specific manual for your display upgrade.

- 1.1 To fit the base display simply open up the clasp and fit around your bikes handlebars.



- 1.2 Tighten the screw on the back of the display using a 3mm Allen key.

 Check your brakes and gear shifters work as normal.

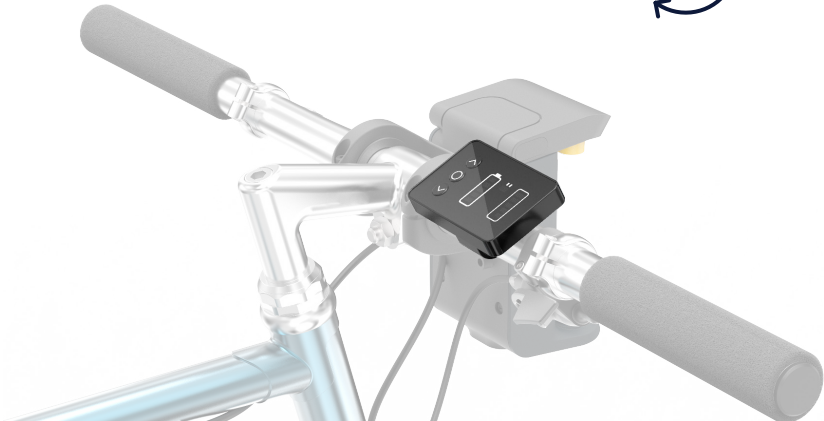
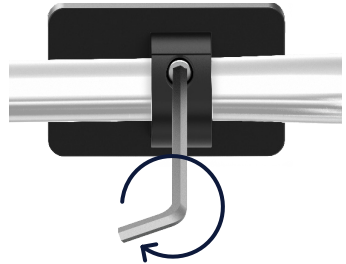

## 6. Connecting Up

The mount has six cables coming out of it, each with a different purpose.

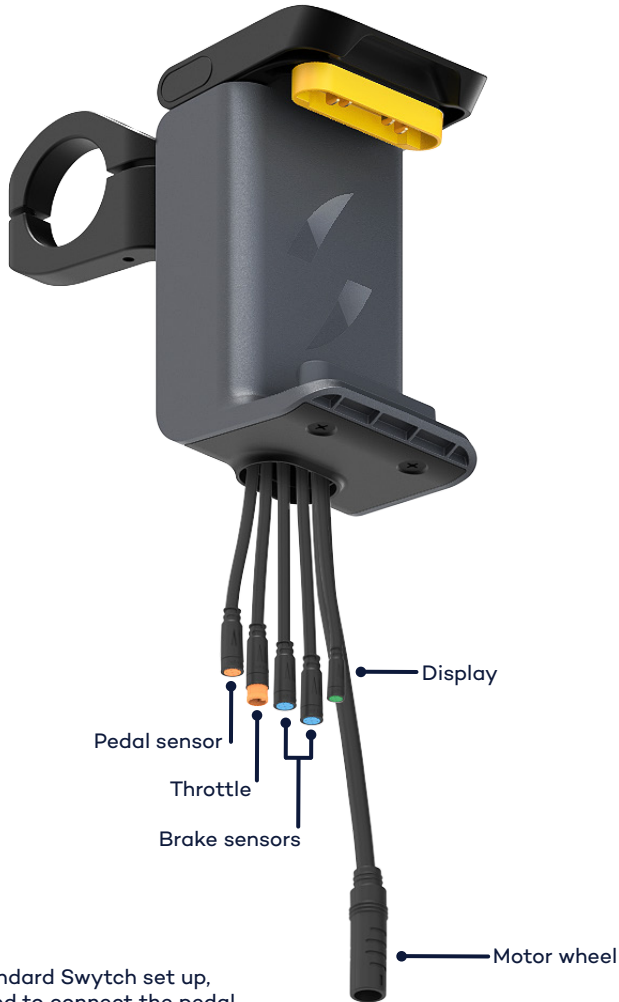

**Note**

For the standard Swytch set up, you will need to connect the pedal sensor, motor wheel and display cable. The remaining cables can be left where they are, or cable tied out of the way.

## 1. Connect the pedal sensor and display

- 1.1 To connect the waterproof connector, find the arrow on each connector and align. Once aligned, push the connector pair together until no colour is visible.

The cable connectors are colour coded. The tall end of the connector connects with the short end.

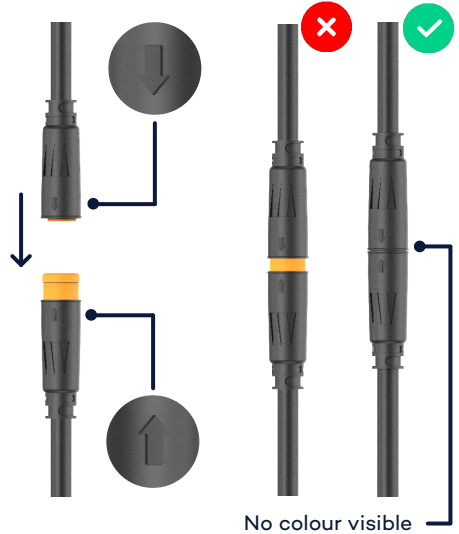

## 2. Connect the motor cable

- 2.1 Connect the motor to the handlebar mount.

To connect the waterproof connector, align the arrows and push together until the arrows touch on both cables.

- 2.2 Secure the motor cable to the fork with the cable ties provided. Leave enough slack for the handlebars to turn.

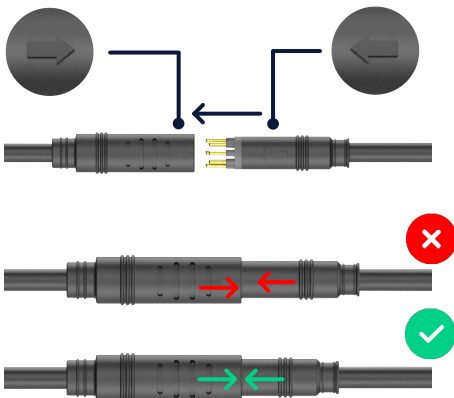

## 7. Routing the Cables

- 1.1 When routing cables to the mount, follow the existing cable routing of your bike. Allow some slack for turning of the handlebars.

Leaving enough slack in the wires is particularly important for folding bikes to allow the bike to still fold as usual.

- 1.2 Loop any extra length of cable back on itself.
- 1.3 Using the cable ties provided, secure everything to your bike.



Make sure the cables aren't in the way when pedaling.



# 3

## Brompton Specific



Swytch Help Centre

1. Torque Washer
2. Magnetic Disc(s)
3. Pedal Sensor
4. Bro Peg
5. Cable Routing

# 1. Torque Washer

1.1 To fit the Brompton torque washer, first thread the motor cable through the keyhole in the washer. Angle the washer with the lip facing towards the forks.

1.2 Remove any of the existing wheel hardware.

1.3 Slot the torque washer into the Brompton forks.

1.4 Tighten and secure the nut, being careful not to pinch the motor cable.

**Note**

If you have a mudguard, assemble it underneath the locking nut.



Ensure the torque washer is fitted correctly.

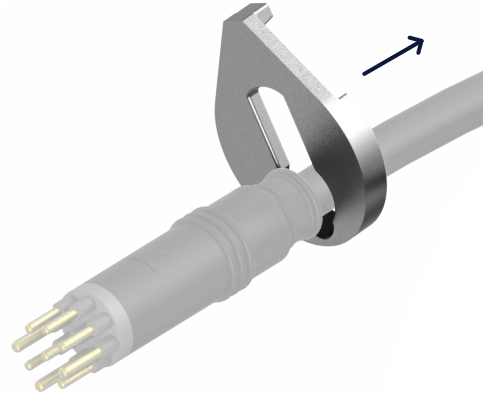





**Note**

If the torque washer is incompatible with your Brompton or if you own a different brand of folding bike, please reach out to us for help.

## 2. Magnetic Disc(s)

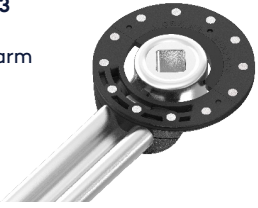
### 1. Choose the correct pedal type

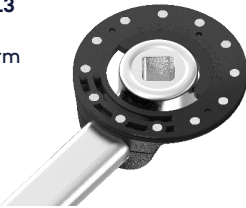
- 1.1 Determine which magnetic disc you need by finding your pedal arm shape in the table below.

What shape is the inside of your pedal arm?	Use this configuration
<p><b>Brompton PRE 2013</b></p> <p>Back of the pedal arm has a concave indentation.</p> 	<p><b>Brompton PAS type A</b></p> 
<p><b>Brompton POST 2013</b></p> <p>Back of the pedal arm has a flat surface.</p> 	<p><b>Brompton PAS type B</b></p> 
<p><b>Non Brompton aftermarket or other folding bike</b></p> <p>If your pedal arm is not one of the previous versions.</p>	<p><b>Universal Magnetic Disc</b></p> <p>See page 23</p> 



## 2. Assemble the parts

2.1 Screw the two-part clamp over the pedal arm. Note, you don't need to remove the pedal arm to do this.

2.2 Tighten the screws with a 2.5mm Allen key.

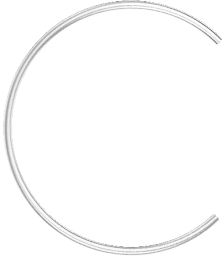

Retention ring

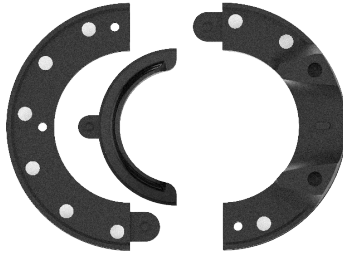

Magnetic disc



Screws

## 3. Check

3.1 This is how it should look when installed correctly.



### 3. Pedal Sensor

1.1 Stick the sensor onto the bottom bracket housing of the Brompton. Angle the sensor so it's sitting within 3mm of the magnetic disc, using spacers if needed.

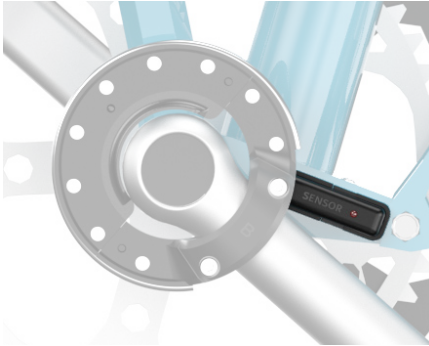

1.2 Tighten the sensor screw to secure it in position and add cable ties to secure it to the frame.

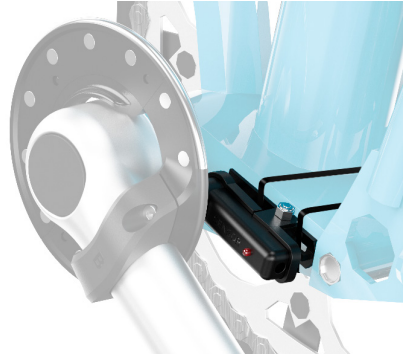

**Note**

If your pedal sensor does not fit in the gap between the frame and the bottom bracket housing then cut off the plastic hinge piece of the sensor and mount directly using the foam spacers and cable ties. This will **not** void your warranty.

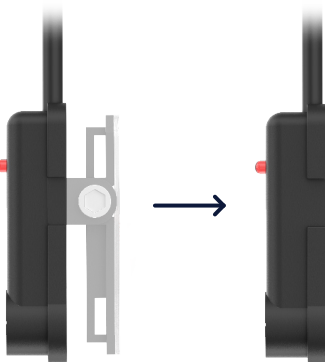

## 4. Bro Peg

### 1. Remove the existing peg

- 1.1 To remove the existing peg from the Brompton frame, rotate it in an anti-clockwise direction.

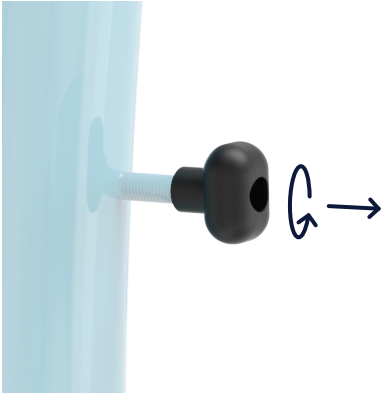

### 2. Install the new Bro Peg

- 2.1 With an adjustable spanner screw the Bro Peg clock-wise until there is 10mm of studding left. Use a ruler to check.

- 2.1 The peg should bend downwards and line up with the latch on the Brompton forks. This might take a few adjustments to align perfectly.

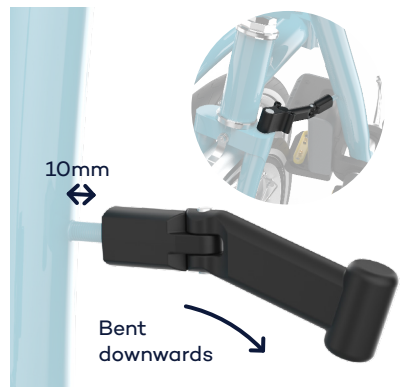

### 3. Finished

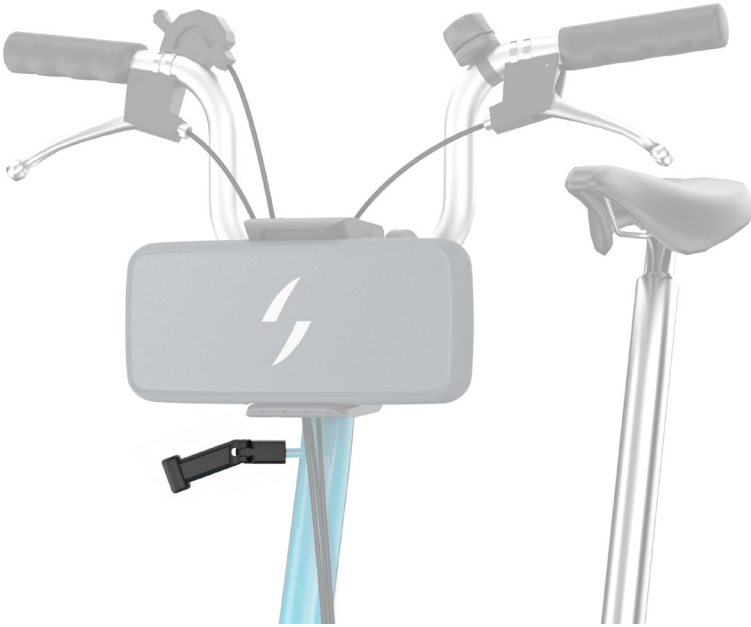

## Brompton Specific

If on your Brompton bike you have front luggage mounted to your luggage mounting point follow the information below.



When your Brompton is upright, your Bro Peg needs to be folded inwards like this.

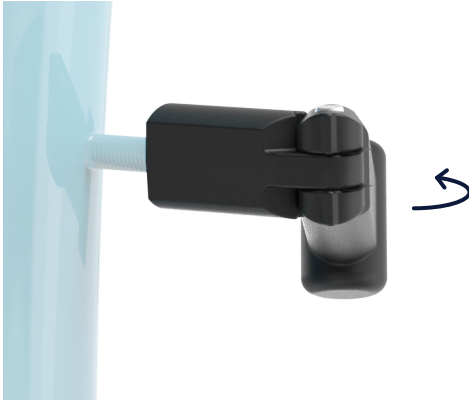

When folding the handlebar of your Brompton, make sure to unfold the Bro Peg.

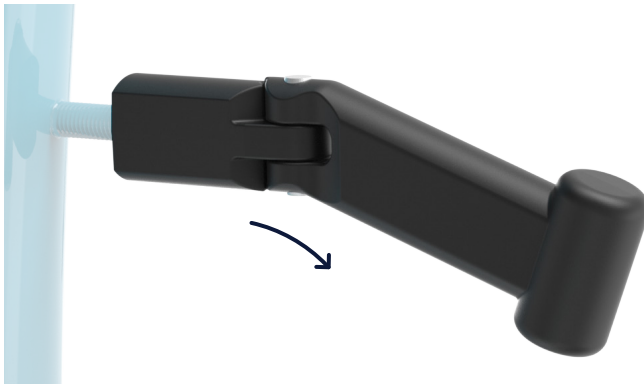

## 5. Cable Routing

1.1 Follow the existing cable routing on your bike. Allow some slack so you can still turn the handlebars and fold your bike with ease.

1.2 Using the cable ties provided, secure everything to your bike.



Make sure the cables aren't in the way when pedaling.



# 4

## Using Your Kit



Swytch Help Centre

1. Power Pack Introduction
2. Starting Your Ride
3. Power Pack Settings
4. Checking Your Battery
5. Ending Your Ride
6. Charging Your Kit

## 1. Power Pack Introduction

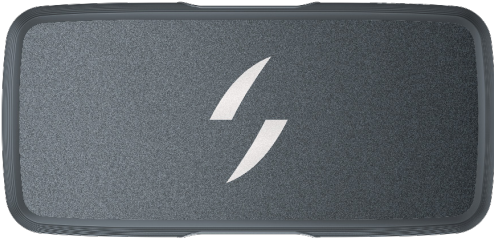

This is the Swytch Power Pack. It has Li-ion cells inside that provide the energy for the Kit.

On the top, you'll find the connector for the handlebar mount and the battery level indicator.



The battery contains dangerous substances, don't disassemble, impact or soak in water.



The Power Pack shouldn't be exposed to temperatures below  $-10^{\circ}\text{C}$  or above  $40^{\circ}\text{C}$ .



## 2. Starting Your Ride

### 1. Connect the Power Pack

- 1.1 Lift up the mount handle so that it's fully open.
- 1.2 Fit the bottom of the Power Pack into the mount alignment block. Then tilt the Power Pack to line up the two yellow connectors.

- 1.3 Push down the mount handle until it's fully engaged.



Avoid trapping anything in the mount mechanism.



Check the connector area is completely dry before connecting to the mount.

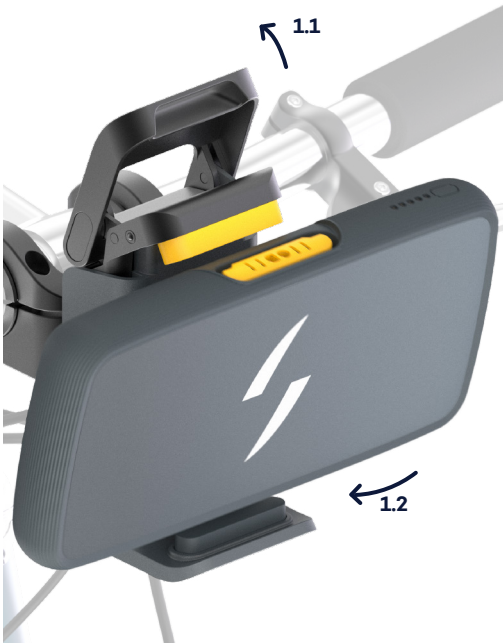

#### Note

In the rare case that your mount handle becomes significantly looser over time, contact our team for advice on how to adjust it.

## 2. Setting your power level

- 2.1 Press and hold down the middle button on the display to turn it on.
- 2.2 Select your power level by pressing the up and down arrows on the display.

 Check your wheel size is correct before your first ride, don't ride your kit with the incorrect wheel size configured.

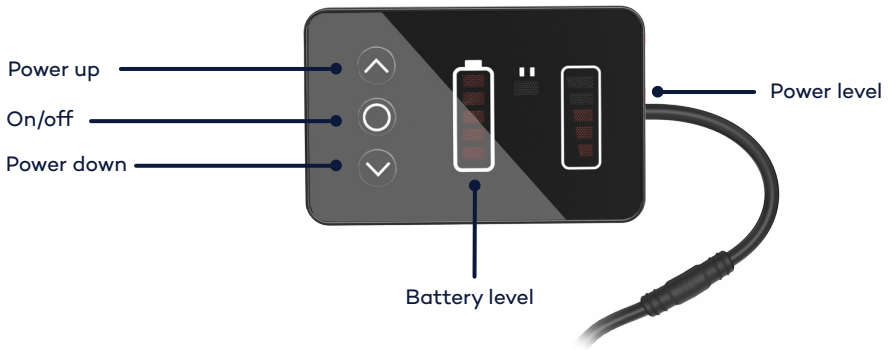

## 3. Test your kit with walk mode

- 3.1 While lifting the front wheel off the floor, press and hold the down button on your display. The front wheel should spin, showing that the Kit has been connected successfully.



### 3. Power Pack Settings

This is how to access and adjust the settings in the Power Pack.

1. Press and hold the up and down arrows together to access the settings.



Once activated, the battery indicator will start flashing.

2. In the settings mode, use the up and down arrows to change the values.

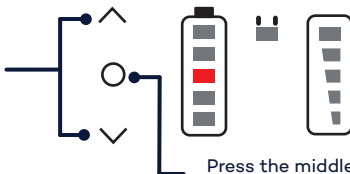

Press the middle button to confirm the value and move onto the next setting.

3.

Factory reset	—	^	•
PAS direction	—	○	•
Power limit	—	○	•
Top speed	—	○	•
Wheel size	—	∨	•

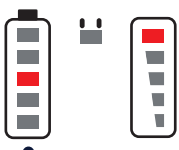

The power level light indicates which value is selected.

The flashing battery light indicates which setting you're adjusting.

4. To exit the settings hold down the middle button, confirming the new values.



These are the different values available for each setting.

## 1. Factory reset

Click the middle button when 'yes' is highlighted to perform the reset.

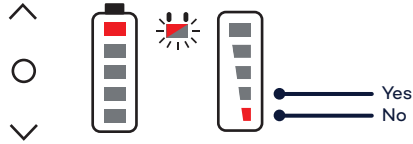

## 2. PAS direction

PAS = Pedal Assist System

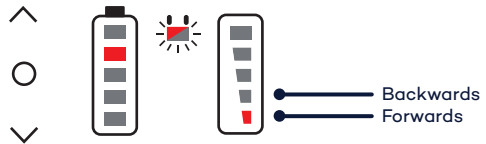

## 3. PAS Activation

Please note the default setting is on level 3 and cannot be changed. The PAS is activated after detecting three magnets.

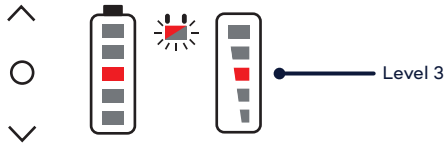

## 4. Top speed

Please note the default setting is 15mph, which is the legal limit for eBikes in the UK/EU.

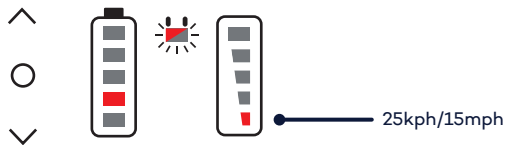

## 5. Wheel size

This should be changed to your wheel size before your first ride.

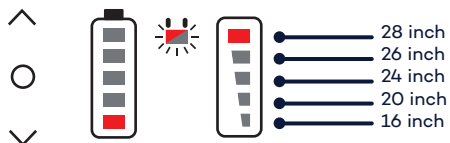

## 4. Checking Your Battery

1.1 Press the battery button located on the top of the Power Pack.

1.2 The LEDs will light up to indicate your battery percentage. Five lights show when its fully charged.



**Note**

The battery LEDs will remain on when connected in the mount.



## 5. Ending Your Ride

- 1.1 To disconnect the Power Pack, lift the mount all the way up.



- 1.2 Remove the Power Pack.

**Note**



To increase battery life remove your Power Pack from the mount when you're not using it.

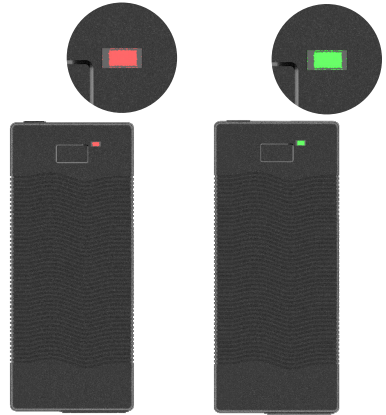

## 6. Charging Your Kit

- 1.1 To charge your Power Pack plug the charger into the yellow connector block as shown.
- 1.2 When the light on the charging brick changes from red to green the Power Pack is fully charged and should be unplugged.



-  Don't charge for extended periods of time.
-  Only use the charger provided to charge the battery.
-  When in storage, please charge every 90 days to maintain the battery life.

# 5

## Troubleshooting



Swytch Help Centre

1. Error Codes
2. Motor Wheel
3. Pedal Sensor
4. Magnetic Disc(s)
5. Mount & Bracket



# 1. Error Codes - Displays

1.1 These are some of the most common error codes you may encounter when using your display.

OLED & LED		BASE Display	
Error Code	Lights	Problem	Action Required
21	Flash at PAS Level 1	Motor current abnormality	Contact customer service
23	Flash at PAS Level 3 & 5	Motor phase abnormality	Contact customer service
24	Flash at PAS Level 5	Motor hall signal abnormality	Contact customer service
25	Flash at PAS Level 3 & 5	Brake abnormality (commonly happens when brakes are engaged before the Power Pack is turned on)	Remove the Power Pack then either:  - disconnect the brake sensors, reattach turn on the Power Pack, then reconnect the brake sensors  - or, turn off the Power Pack, ensure the brakes are released, then turn the Power Pack back on
30	Flash at all levels and both PAS and Battery	Communication abnormality (Controller and Display aren't connected)	Check the display is connected to the mount

## 2. Motor Wheel isn't Spinning Freely

- 1.1 Ensure that the brakes are adjusted correctly and aren't touching the rim.
- 1.2 Next, check if the motor casing is touching the forks. If it is, you need to increase the gap between the forks. The best way to fix this is to add a washer to the axle as shown.

Washer fitted inside fork

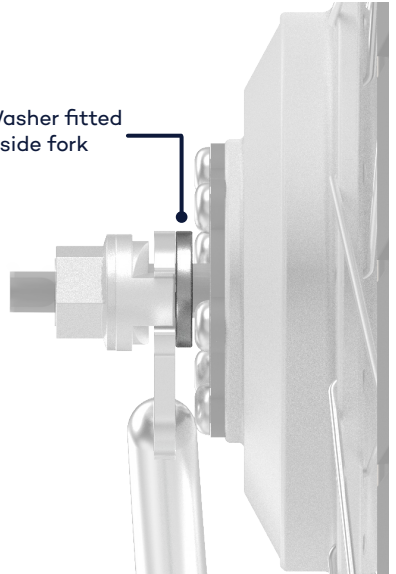

- 1.3 Alternatively, move the torque washer inside the forks instead of the washer.

The torque washer will push the forks out, so you may need to apply some pressure to seat the fork over the torque washer.

Torque washer fitted inside fork

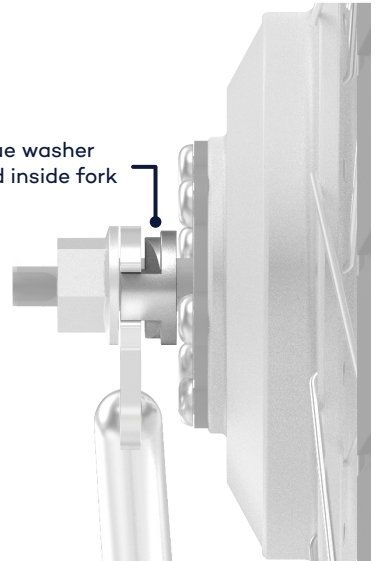

### 3. Pedal Sensor Magnetic Disc Doesn't Fit My Bike

- 1.1 If there isn't enough space, cut off the plastic hinge piece of the sensor and mount directly using cable ties. This will **not** void your warranty.

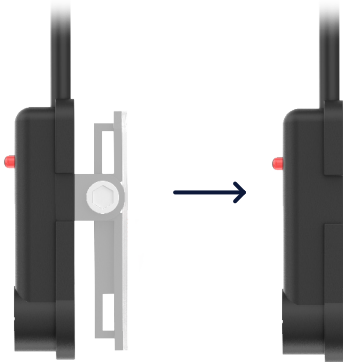

### 4. Motor Starts and Stops When Using Pedal Assist

- 1.1 If the pedal assist power is intermittent, make sure that the magnetic disc isn't wonky. Straighten it and adjust the sensor so that it's closer to the magnetic disc.

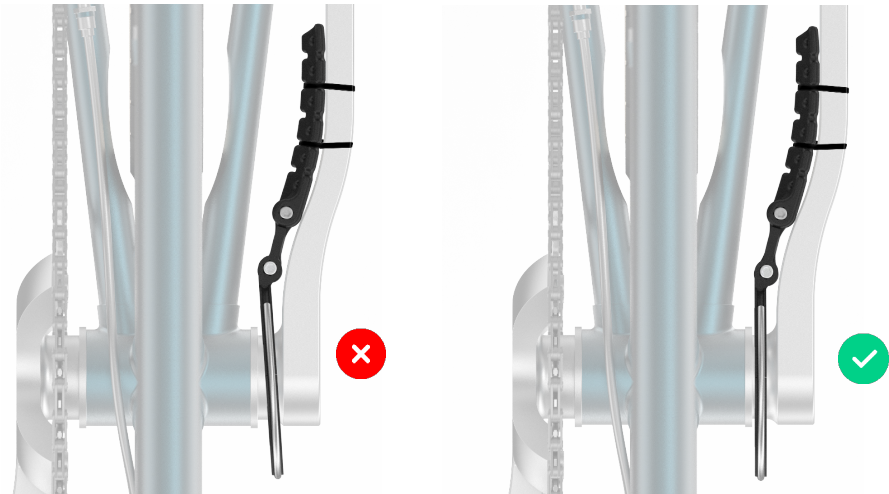

## 5. Handlebar Mount Moves

1.1 Check that the screws are tight.

1.2 Change/ add a spacer to get a tighter fit.



Too tight

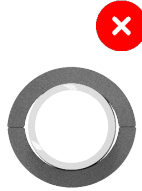

Too loose



Perfect fit

# 6

## Kit Care



Swytch Help Centre

1. Maintenance

2. Warranty Terms

## Maintenance

Interval (whichever is first)	Swytch Kit	Bike
Every ride	<ul style="list-style-type: none"> <li>- Recharge the Power Pack</li> <li>- If installed, test the brake sensors operate normally</li> </ul>	<ul style="list-style-type: none"> <li>- Tyre pressure</li> <li>- Check tyres for debris/ thorns</li> <li>- Check brakes</li> </ul>
Monthly 20 hours 500 miles	<ul style="list-style-type: none"> <li>- Top up battery charge if storing over winter</li> <li>- Check motor wheel nuts are tight</li> <li>- Make sure pedal sensor is aligned</li> </ul>	<ul style="list-style-type: none"> <li>- Adjust brakes</li> <li>- Lubricate chain</li> <li>- Look for tyre wear</li> </ul>
6 months 100 hours 3000 miles	<ul style="list-style-type: none"> <li>- Test motor wheel spoke tension</li> <li>- Check motor and sensor connectors</li> <li>- Check throttle and PAS function normally</li> <li>- Inspect Power Pack for any damage</li> <li>- Check handlebar mount for any damage</li> </ul>	<ul style="list-style-type: none"> <li>- Deep clean drive parts.</li> <li>- Ensure that your rims are true, without any wobble</li> </ul>
12 months 200 hours 6000 miles	<ul style="list-style-type: none"> <li>- Check motor wheel turns smoothly and quietly</li> </ul>	<ul style="list-style-type: none"> <li>- Replace drive parts if necessary</li> <li>- Regrease bearings if necessary</li> </ul>

## Swytch Bike Warranty Terms

The full terms of Swytch Bike's warranty are outlined below (as of 22 May 2019)

Swytch Bike guarantees the product to be free from defects in materials and workmanship for a period of one year from date of delivery.

Registration of the product is subject to all customers completing a post-installation form, by submitting photos and videos of their installed kit. The Swytch Bike technical team can then review the submission to ensure that everything is as it should be and the kit is installed correctly. This checkup can be completed at any time, but the activation will not be final until it's approved.

**To register your product please visit <https://support.swytchbike.com/hc/en-gb> and search 'Product Registration.'**

If within the warranty period, the product is determined to be defective due to improper materials or workmanship, Swytch Bike will, without charge for labour or parts, repair or (at Swytch Bike's discretion) replace the product or its defective parts subject to the terms and limitations below.

Swytch Bike may replace defective products or parts with new or refurbished products or parts. All products and parts replaced become the property of Swytch Bike.

### Terms and Conditions

Guarantee services will be provided only if the defective product is presented within the guarantee period. Swytch Bike may refuse free-of-charge guarantee service if the product is not presented within this time period. This guarantee won't apply if the model name or serial number on the product has been altered, deleted, removed or made illegible.

This guarantee doesn't necessarily cover transport costs and risks associated with the transport of your product to and from Swytch Bike. This Guarantee is exclusive to the purchaser and is dependent on the customer providing relevant proof of purchase.

This guarantee doesn't cover:

– Misuse, including:

Treatment resulting in physical, cosmetic or surface damage or changes to the product; failure to install or use the product for its normal purpose or in accordance with instructions on installation or use; failure to maintain the product in accordance with instructions on proper maintenance; installation or use of the product in a manner inconsistent with the technical or safety laws or standards in the country where it's installed or used.

– Use of the product with accessories, peripheral equipment and other products of a type, condition and standard other than prescribed by Swytch Bike.

- Repair or attempted repair by persons who aren't Swytch Bike approved.
- Adjustments or adaptations without Swytch Bike's prior written consent, including:

Upgrading the product beyond specifications or features described in the instruction manual, or modifications to the product to conform it to national or local technical or safety standards in countries other than those for which the product was specifically designed and manufactured;

Neglect;

Accidents, fire, liquids, chemicals, other substances, flooding, vibrations, excessive heat, improper ventilation, power surges, excess or incorrect supply or input voltage, radiation, electrostatic discharges including lightning, other external forces and impacts.

Exclusions and limitations except as stated above, Swytch Bike makes no warranties (express, implied, statutory or otherwise) regarding product or accompanying or constituent accessories quality, performance, accuracy, reliability, fitness for a particular purpose, or otherwise.

If this exclusion is not permitted or fully permitted by applicable law, Swytch Bike excludes or limits its warranties only to the maximum extent permitted by applicable law. Any warranty that cannot be fully excluded will be limited (as far as permitted by applicable law) to the duration of this guarantee.

Swytch Bike's only obligation under this guarantee is to repair or replace products subject to these guarantee terms and conditions.

Swytch Bike is not liable for any loss or damage relating to products, service, this guarantee or otherwise, including – economic or intangible losses – the price paid for the product – loss of profits, revenue, data, enjoyment or use of the product or any associated products – indirect, incidental or consequential loss or damage.

Your legal rights reserved. This guarantee doesn't affect statutory rights you may have nor those rights that cannot be excluded or limited, nor rights against the person from whom you purchased the product. You may assert any rights you have at your sole discretion.







Swytch Technology Ltd,  
Unit 2A  
455 Wick Lane  
London  
E3 2TB

Watch the installation video!  
Scan here.

